

MP-830

Motor System Protection Relay
Underload Restart Timer
Three Phase

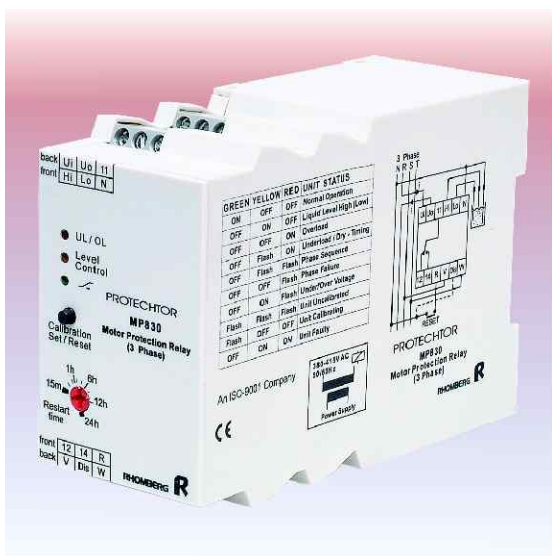

ORDERING CODE



Application Examples

- Comprehensive Motor System Protection against conditions of underload, overload and supply fluctuations.
- Detection of conveyor belt breaks.
- Detection of clogged fan filters in spray paint installations.
- Protection of 3 phase induction motors against conditions of single phasing, phase failure and phase sequence.
- Protection of pumps against running dry, closed outlet valve or no-flow (centrifugal pumps).

Features

- Underload sensing by measuring the phase angle.
- Adjustable restart time after detection of underload conditions.
- Overload sensing by measuring the current amplitude.
- Microprocessor-based technology.
- Direct in-line current sensing of motors up to 3.7kW.
- Auto-calibration of overload and underload limits.
- Auto-calibration of overvoltage and undervoltage limits.
- Direct interface with a conventional current transformer.
- Phase sequence and phase failure detection.
- Liquid level control (programmable for charge or discharge).
- External control (programmable for normally open/closed contacts).
- Start-up delay (fixed, 3 seconds standard).
- Latching on overload conditions.
- Fail-to-safe design.
- Din-rail mount.
- 5A SPDT relay output.

Description of Operation

The Protektor MP-830 is a multi-featured relay providing comprehensive protection for 3 phase AC induction motor systems. The unit is a phase angle, current sensing and voltage sensing relay, that can automatically set up trip points within specified limits around the normal operating conditions of a particular motor system. An adjustable restart timer, triggered by an underload fault can be used to restart the motor system after a pre-set time. Motor Systems up to 3.7kW can be protected without the use of an external current transformer. An external current transformer must be used for motors higher than 3.7kW.

Calibration

Auto Calibration: If the unit is not in Uncalibrated Mode, with all LED's flashing simultaneously, see Calibration Reset below. To start auto calibration, power the unit up in Uncalibrated Mode. Press the **Calibration Set/Reset** pushbutton and hold it until only the green Relay ON LED starts flashing (approx. 5 seconds). The unit will now monitor the load of the motor and set up the overload, underload and voltage limits (this will take approx. 10 seconds). If calibration is successful the green Relay ON LED will stop flashing and stay on. If calibration is unsuccessful, the unit will return to the uncalibrated mode with all LED's flashing simultaneously. This means that the motor's load is outside the unit's specified calibration range (see Technical Specifications).

Note: If calibration is unsuccessful, check the current direction (reverse if necessary), or the current magnitude (use an external CT if above 8Amps).

Calibration Reset: The calibration limits can be reset when required by the user. Remove power from the unit. Press the Calibration Set/Reset pushbutton and apply power to the unit. The green Relay ON LED will illuminate. Hold the pushbutton down until all the LED's start flashing (approx. 3 seconds). This will reset the calibrated limits and return the unit to uncalibrated mode.

Uncalibrated Mode: The unit is supplied uncalibrated from the factory. When power is applied to the unit all LED's will flash simultaneously and the relay energises to supply power to the motor.

Note: The motor is unprotected in this mode and care should be taken before applying power. The unit will only respond to phase sequence or phase failure faults.

Normal Operation

Start-up Delay: When power is applied to the unit, the relay energises immediately, ignoring abnormal load conditions experienced during initiation. This time is fixed at 3 seconds.

Latching Faults

Overload Sensing: If the current exceeds the set limit stored during calibration the relay will de-energise after a 3 second response time. The unit will latch in this condition (see Faults Reset).

Faults Reset: If the unit latches in a fault condition, the relay will remain de-energised until reset. A reset can be performed by either connecting the reset input (R) to neutral (N) via an external switch or cycling the power supply to the unit. Where Neutral is not available, an Earth connection must be used (if permitted by regulations).

Reset Lockout: If the system is reset more than 3 times in a 15 min period the reset lockout is enabled, prohibiting continuous resetting when a fault condition exists. Cycling the power supply to the unit will override the reset lockout and reset

the unit.

Caution: When using the reset input or cycling the power supply to the unit, the relay will be forced to energise even though a fault may exist. This could cause damage to equipment, therefore the fault must first be repaired before attempting to run the motor.

Non-latching Faults

Phase Sequence: If any two phases to the motor are reversed, the relay will de-energise immediately. When the phase sequence has been restored, the relay automatically energises and the motor will start again.

Phase Failure: The unit will monitor the loss of any phase in the 3 phase supply to the motor, causing the relay to de-energise immediately, in conditions of up to 80% voltage regeneration. When the voltage has stabilised within safe limits, the relay automatically energises and the motor will start again.

Voltage Sensing: If the supply voltage increases or decreases by more than 10% of nominal, the relay will de-energise and the motor will be switched off. When the voltage has stabilised within safe limits, the relay automatically energises and the motor will start again.

Underload Sensing: In an induction motor, the current always lags the voltage. By measuring this angular lag, an underload fault can be sensed. Loss of load will cause the angular lag to increase. When it exceeds the set limit stored during calibration, the relay will de-energise after a 1 sec response time. The restart timer will now start timing (see Restart Timer).

Control Functions

Level Control: The unit can monitor the level of conductive liquids. By using three probes, the unit controls the level of the liquid in a reservoir between a low and a high level. The unit normally operates in the Charging (Filling) mode, but can be programmed to the Discharging (Draining) mode by means of an external wire link.

Charging (Filling): [No external wire link.] The relay will energise when the liquid level drops below the low level probe. The relay will remain energised until the level reaches the high level probe. When the high level probe becomes submerged, the relay de-energises and remains off until the liquid level has dropped sufficiently to clear the low level probe.

Discharging (Draining): Link terminals Dis (discharging) and N (neutral). The relay will energise when the liquid level rises above the high level probe. The relay will remain energised until the level drops to below the low level probe. The relay then de-energises and remains off until the liquid level has risen sufficiently to submerge the high level probe.

External Control: The liquid level inputs can be used as a general-purpose external control to switch the relay on and off. If both high (Hi) and low (Lo) level inputs are connected to Neutral (N), the relay will de-energise and similarly, if both Hi and Lo are disconnected, the relay will energise. (With terminals Dis and N linked, the relay will operate in the opposite sense.)

Restart Timer: The restart timer is triggered by an underload condition. The unit will attempt to restart the motor when the set time elapses to check if the fault still exists. If an underload fault still exists after a restart attempt, the relay will de-energise, re-triggering the restart timer. The above procedure will be repeated.

Operational Diagrams

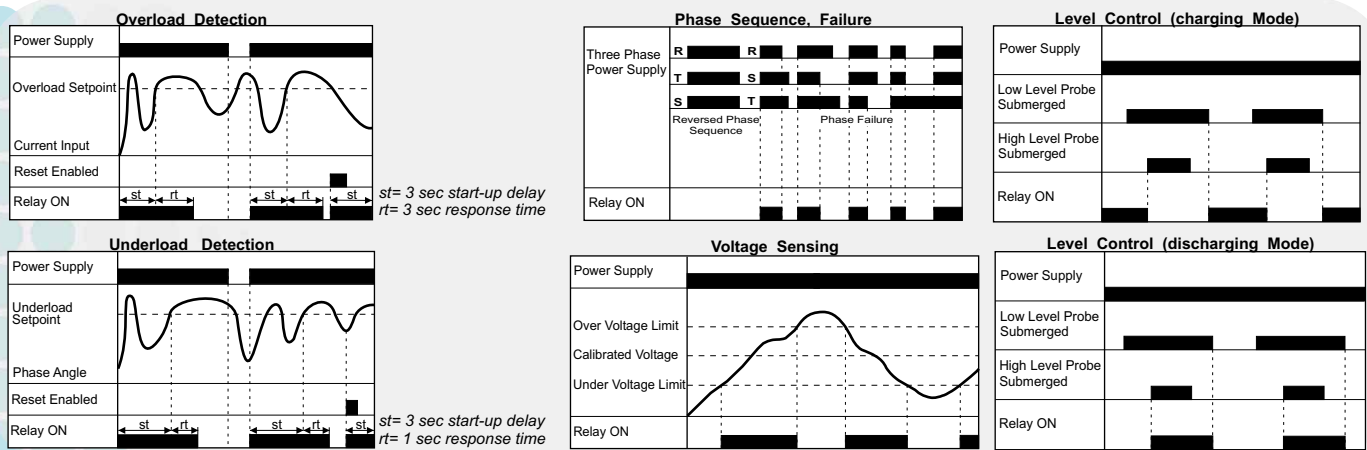

Description of Controls

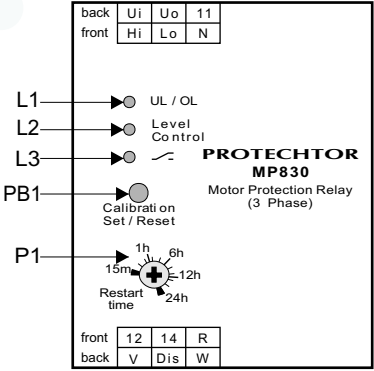

L1: The red "UL / OL" LED.
 L2: The yellow "Level Control" LED.
 L3: The green "Relay ON" LED.

Note: Collectively the 3 LED's indicate the status of Unit, see Table 1.

P1: **Restart Time** is set on P1. This time period is adjustable from 15 min to 24 hrs.

PB1: **Calibration Set / Reset** is initiated with PB1.
 Calibration Set: Refer to Calibration under Description of Operation above.
 Calibration Reset: Refer to Calibration Reset under Description of Operation above.

TABLE 1:

GREEN	YELLOW	RED	UNIT STATUS
ON	OFF	OFF	Normal Operation
OFF	ON	OFF	Liquid Level High (Low)
OFF	OFF	ON	Overload
OFF	Flash	ON	Underload/Dry Timing
OFF	Flash	Flash	Phase Sequence
OFF	OFF	Flash	Phase Failure
OFF	ON	Flash	Under/Over Voltage
Flash	Flash	Flash	Unit Uncalibrated
Flash	OFF	OFF	Unit Calibrating
OFF	ON	ON	Unit Faulty

Wiring and Connection

Power Supply

Phase S	V
Phase T	W

Relay Contacts

Normally Open	11+14
Normally Closed	11+12

Level Control

High level probe	Hi
Low level probe	Lo
Common probe	N

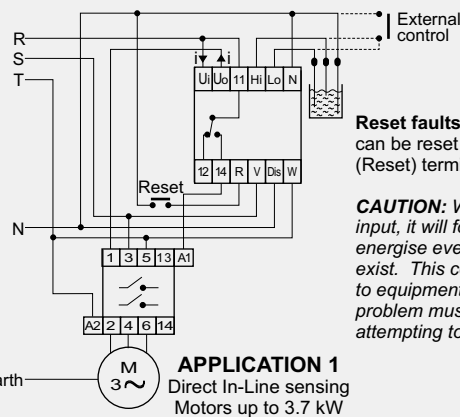

Reset faults: All fault conditions can be reset by connecting the R (Reset) terminal to E (Earth).

CAUTION: When using the reset input, it will force the relay to energise even though a fault may exist. This could cause damage to equipment, therefore the problem must first be fixed before attempting to run the motor.

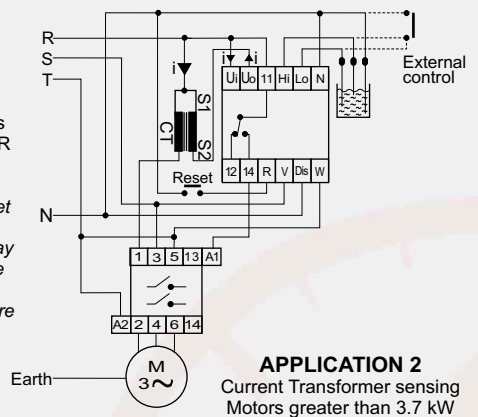

Technical Specifications

Nominal Supply Voltage	220 - 240V AC	380 - 415V AC	525V AC
Supply Voltage Tolerance	176 - 288V AC	304 - 498V AC	420 - 630V AC
Supply frequency	50/60Hz		
Isolation (current input to power supply)	2kV		
Power Consumption	4VA (approx.)		

Current Input

Motors <3.7kW:

Current limits to ensure calibration	0,5 to 8A
Repetitive accuracy	1%
Maximum input current (continuous)	12A

Motors >3.7kW: (use external CT)

CT Example: 380/400/415V

Motor	5.5kW	7.5kW	11kW	15kW	18.5kW	22kW	30kW	37kW	45kW
CT	15/5	20/5	30/5	40/5	50/5	50/5	75/5	100/5	100/5

Relay

250V, 5A	SPDT
----------	------

Level Control

Sensitivity	50 kΩ
-------------	-------

Restart

Restart Timer (underload)	15 min - 24 hrs (adjustable)
Reset lockout	Max. 3 resets per 15 minutes

Calibration

Phase Angle Limits: Underload	90° or 125% of calibration value
Current Limits: Overload	10A or 125% of calibration value
Voltage Limits:	±10% of calibration value

Response

Start-up Delay	3 seconds fixed, standard (extended times available on request)
Response Delay	Overload 3 seconds Phase sequence/ failure instantaneous on all other faults 1 second